

DB951WP General Specification.

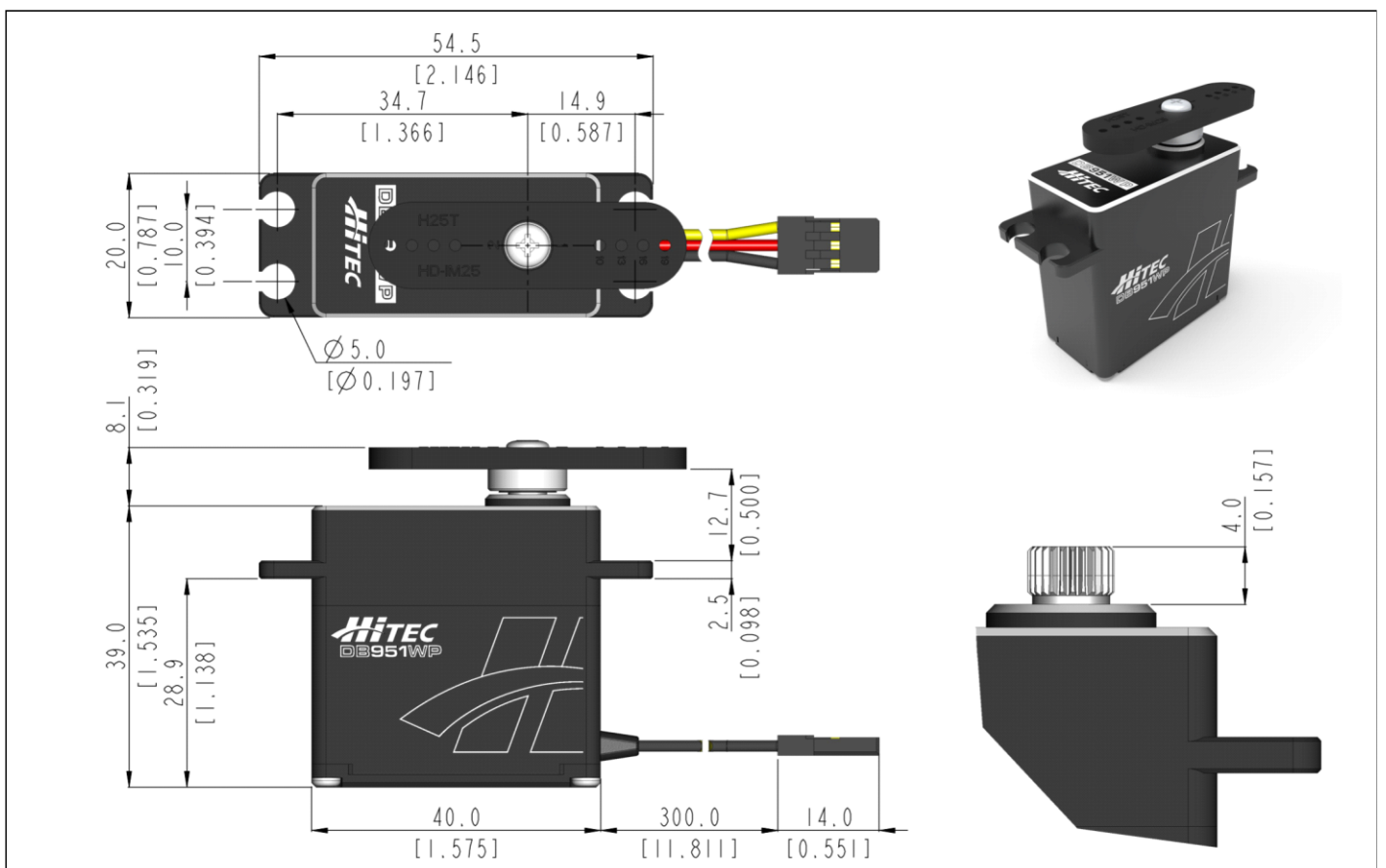

Control System	PWM/TTL(Half Duplex)		-
Position Sensor Type	Contact Analog Potentiometer		-
Motor Type	BLDC		At the Max voltage, it is recommended to be used only for a short time duration.
Operating Voltage Range	4.0 ~ 8.4V		
Voltage	-	6.0V	7.4V
No Load Speed	-	0.12sec/60°	0.10sec/60°
Stall Torque	-	38.0kgf-cm (527.72oz-in)	38.0kgf-cm (527.72oz-in)
Peak Efficiency Torque	-	7.6kgf-cm (105.54oz-in)	7.6kgf-cm (105.54oz-in)
Standing Current	-	35mA	35mA
No Load Running Current	-	350mA	350mA
Stall Current	-	8,000mA	6,500mA
Deadband	-	1μs	1μs
Operating Travel	Default: ±60°, Programmable: Max 260° / Pulse Width: 900~2100μs(Center:1500μs)		-
Continuous Rotation	n/a		-
Operating Temperature Range	-20°C ~ +60°C (-4°F ~ +140°F)		-
Storage Temperature Range	-30°C ~ +80°C (-22°F ~ +176°F)		-
Connector Wire Length	300mm (11.811inch)		
Connector Wire Gauge	20AWG		
Dimensions	40.0mm x 20.0mm x 39.0mm (1.575inch x 0.787inch x 1.535inch)		General Tolerance ±0.1mm
Weight	90.0g (3.175oz)		Excluding the weight of Horn
Bearing Type	2 Ball Bearing		-
Case Material	Aluminum Alloy		-
Gear Material	5 Hardened Steel Gears		-
Gear Train Backlash	Max 0.5°		-
Horn Gear Spline	25T(Ø6)		-
IP-Rating	IP67		-
Servo Amplifier Type	16bit programmable Digital		-



1:1 scale (Unit : mm[inch])

- This product should not be used directly on the human body for medical purposes.
- This product should not be used for war weapons.
- All specifications are subject to change without notice.

