

HS-40 General Specification.

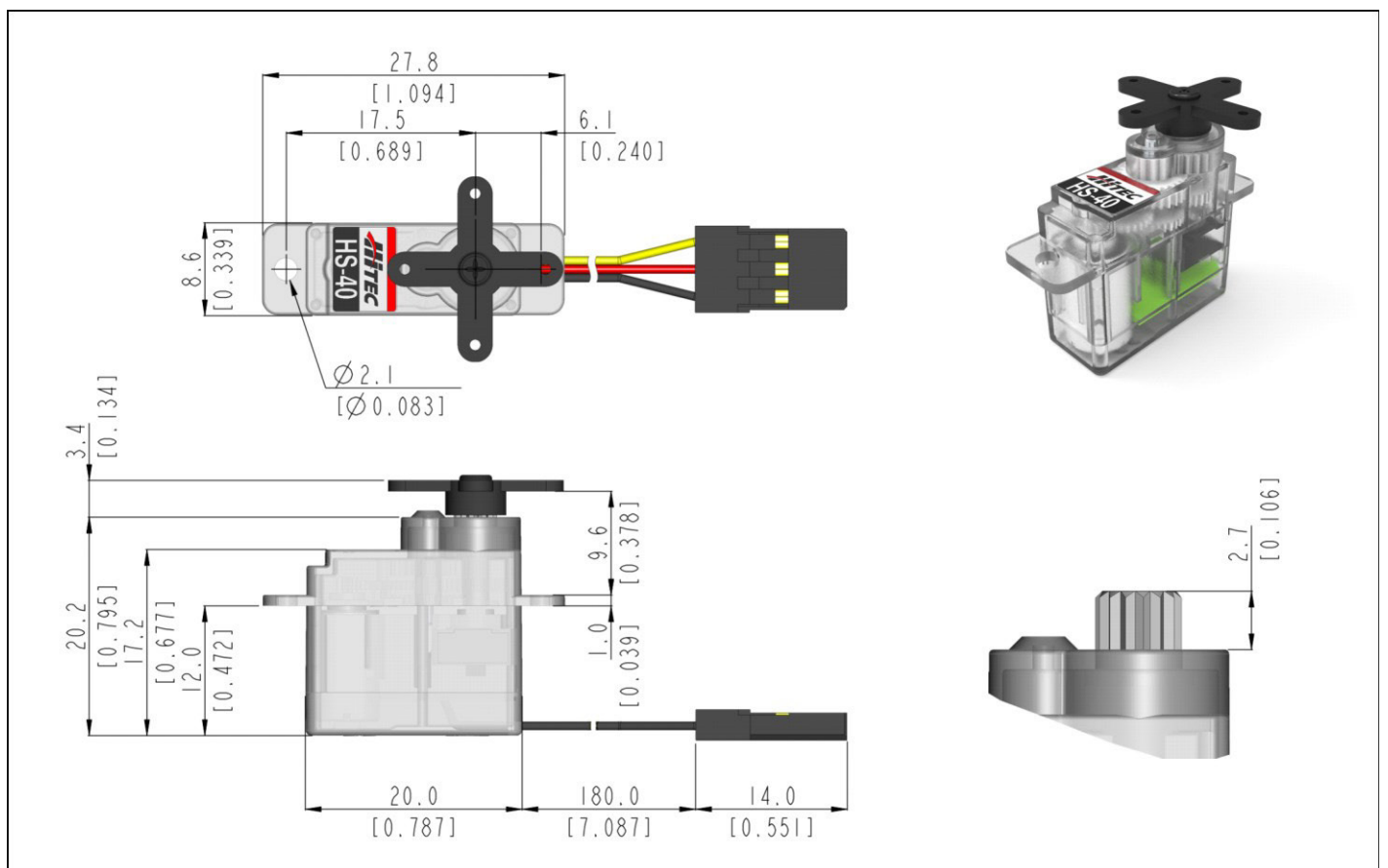

Control System	PWM			-
Position Sensor Type	Contact Analog Potentiometer			-
Motor Type	Coreless			At 25°C(±10%), 45%RH(±10%) <u>measurement environment</u>
Operating Voltage Range	4.8 ~ 6.0V			
Voltage	4.8V	-	-	
No Load Speed	0.09sec/60°	-	-	
Stall Torque	0.6kgf·cm (8.33oz·in)	-	-	
Peak Efficiency Torque	0.1kgf·cm (1.4 oz·in)	-	-	
Standing Current	8mA	-	-	
No Load Running Current	60mA	-	-	
Stall Current	460mA	-	-	
Deadband	5μs	-	-	
Operating Travel	Default: ±60°, Non-programmable / Pulse Width: 900~2100μs(Center:1500μs)			-
Continuous Rotation	n/a			-
Operating Temperature Range	-20°C ~ +60°C (-4°F ~ +140°F)			-
Storage Temperature Range	-30°C ~ +80°C (-22°F ~ +176°F)			-
Connector Wire Length	180mm (7.087inch)			
Connector Wire Gauge	28AWG			
Dimensions	20.0mm x 8.6mm x 17.0mm (0.787inch x 0.339inch x 0.669inch)			General Tolerance ±0.1mm
Weight	4.8g (0.169oz)			Excluding the weight of Horn
Bearing Type	N/A			-
Case Material	Engineering Plastic			-
Gear Material	5 Resin Gears			-
Gear Train Backlash	Max 0.5°			-
Horn Gear Spline	15T(Ø4.0)			-
IP-Rating	IP4X			-
Servo Amplifier Type	Analog Contorller			-



3:2 scale (Unit : mm[inch])

- This product should not be used directly on the human body for medical purposes.
- All specifications are subject to change without notice.



9001:2015
14001:2015
CERTIFIED



HitecCS.com