

HS-805MG General Specification.

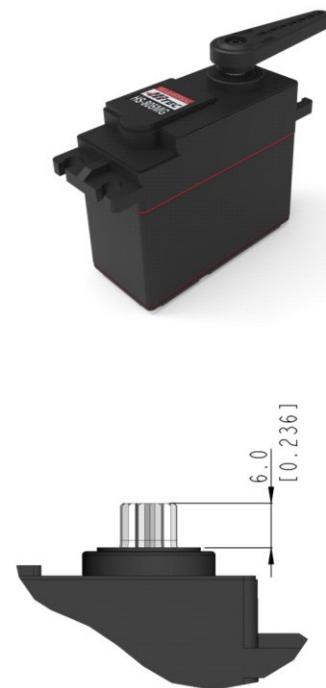

Control System	PWM			-
Position Sensor Type	Contact Analog Potentiometer			-
Motor Type	Cored Carbon brush			At 25°C(±10%), 45%RH(±10%) measurement environment
Operating Voltage Range	4.8 ~ 6.0V			
Voltage	4.8V	6.0V	-	
No Load Speed	0.19sec/60°	0.14sec/60°	-	
Stall Torque	19.8kgf·cm (274.97oz·in)	24.7kgf·cm (343.02oz·in)	-	
Peak Efficiency Torque	4.0kgf·cm (55.5 oz·in)	4.9kgf·cm (68.0 oz·in)	-	
Standing Current	8mA	10mA	-	
No Load Running Current	400mA	520mA	-	
Stall Current	4,800mA	6,000mA	-	
Deadband	5μs	5μs	-	
Operating Travel	Default: ±60°, Non-programmable / Pulse Width: 900~2100μs(Center:1500μs)			-
Continuous Rotation	n/a			-
Operating Temperature Range	-20°C ~ +60°C (-4°F ~ +140°F)			-
Storage Temperature Range	-30°C ~ +80°C (-22°F ~ +176°F)			-
Connector Wire Length	300mm (11.811inch)			
Connector Wire Gauge	22AWG			
Dimensions	66.3mm x 30.3mm x 57.6mm (2.610inch x 1.193inch x 2.268inch)			General Tolerance ±0.1mm
Weight	197.0g (6.949oz)			Excluding the weight of Horn
Bearing Type	2 Ball Bearing			-
Case Material	Engineering Plastic			-
Gear Material	1 Resin & 4 Metal Gears			-
Gear Train Backlash	Max 0.5°			-
Horn Gear Spline	15T(Ø8)			-
IP-Rating	IP54			-
Servo Amplifier Type	Analog Contorller			-

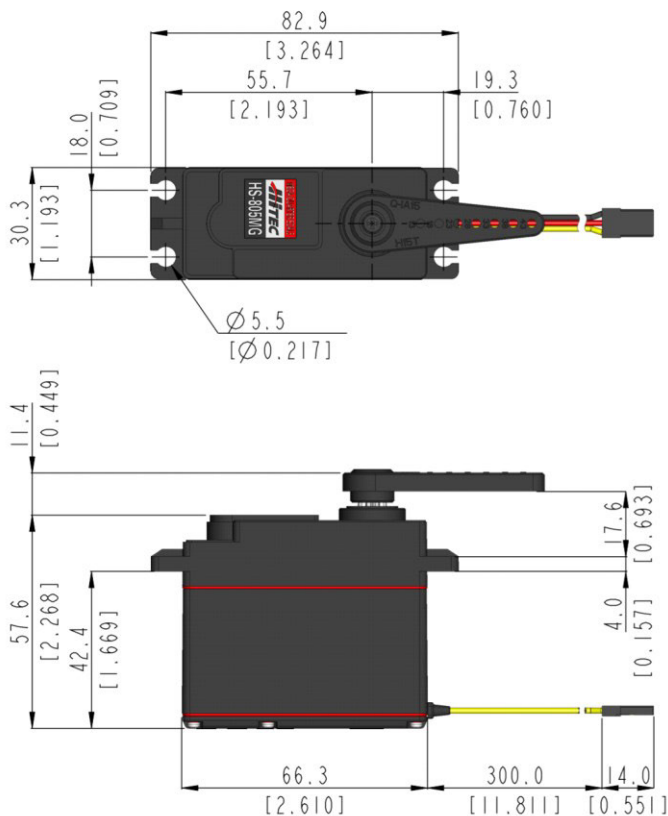

1:2 scale (Unit : mm[inch])

- This product should not be used directly on the human body for medical purposes.
- All specifications are subject to change without notice.



HitecCS.com