

MD65MG-CAN General Specification.

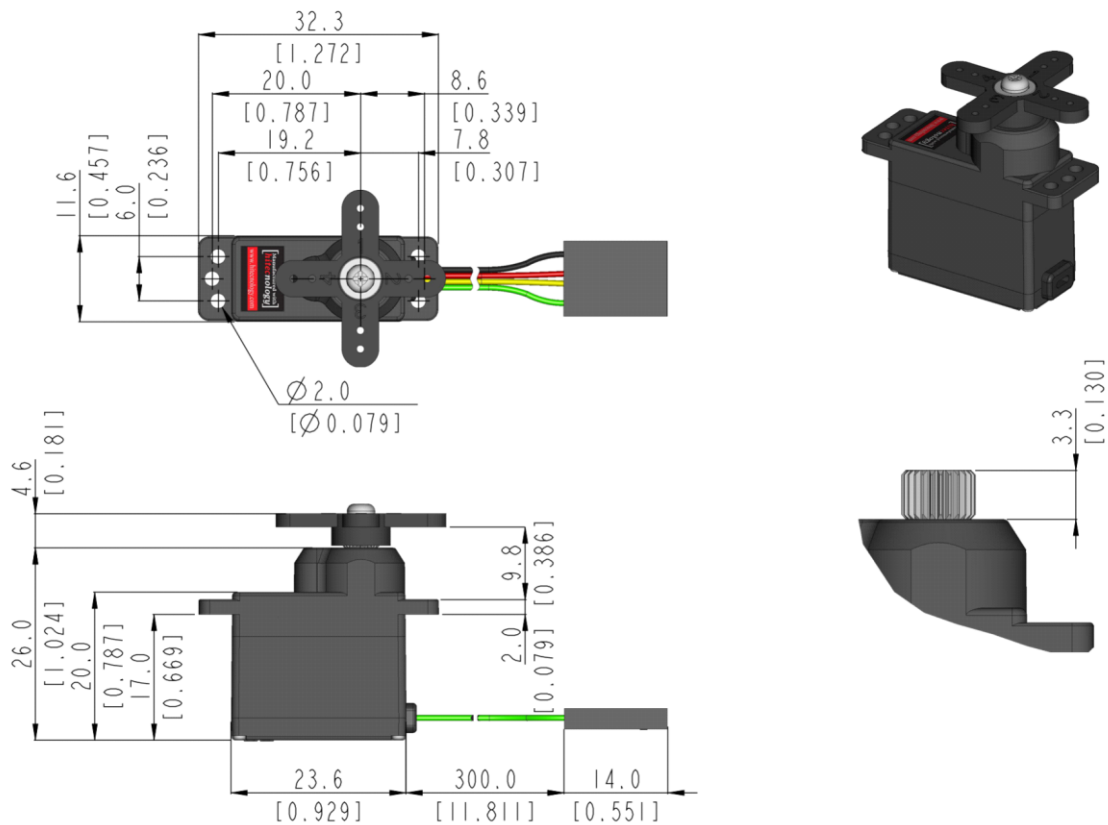

Control System	CAN 2.0A,B			-	
Position Sensor Type	Contactless Magnetic Encoder			-	
Motor Type	Cored Metal Brush			At the Max voltage, it is recommended to be used only for a short time duration.	
Operating Voltage Range	4.0 ~ 8.4V				
Voltage	4.8V	6.0V	-	At 25°C(±10%), 45%RH(±10%) <u>measurement environment</u>	
No Load Speed	0.14sec/60°	0.11sec/60°	-		
Stall Torque	1.8kgf-cm (25.0 oz-in)	2.2kgf-cm (30.55oz-in)	-		
Peak Efficiency Torque	0.4kgf-cm (5.55oz-in)	0.4kgf-cm (5.55oz-in)	-		
Standing Current	30mA	30mA	-		
No Load Running Current	180mA	220mA	-		
Stall Current	960mA	1,200mA	-		
Deadband	n/a	n/a	-		
Operating Travel	Servo Mode : ±60°(Default), ±150°(Programmable) / Turn Mode : ±32760 Turns				F/W v1.5 or Higher version
Continuous Rotation	n/a				-
Operating Temperature Range	-20°C ~ +60°C (-4°F ~+140°F)			-	
Storage Temperature Range	-30°C ~ +80°C (-22°F ~+176°F)			-	
Connector Wire Length	300mm (11.811inch)				
Connector Wire Gauge	28AWG				
Dimensions	23.6mm x 11.6mm x 26.0mm (0.929inch x 0.457inch x 1.024inch)			General Tolerance ±0.1mm	
Weight	12.8g (0.452oz)			Excluding the weight of Horn	
Bearing Type	1 Ball Bearing			-	
Case Material	Engineering Plastic			-	
Gear Material	1 Heavy Duty Resin & 4 Metal Gears			-	
Gear Train Backlash	Max 0.5°			-	
Horn Gear Spline	M25T(Ø5)			-	
IP-Rating	IP4X			-	
Servo Amplifier Type	32bit programmable Digital			-	



1:1 scale (Unit : mm[inch])

- This product should not be used directly on the human body for medical purposes.
- All specifications are subject to change without notice.
- Be careful as strong magnetic fields may cause malfunction of the product.



9001:2015
14001:2015
CERTIFIED



HitecCS.com