

# MD65MG-DroneCAN General Specification.

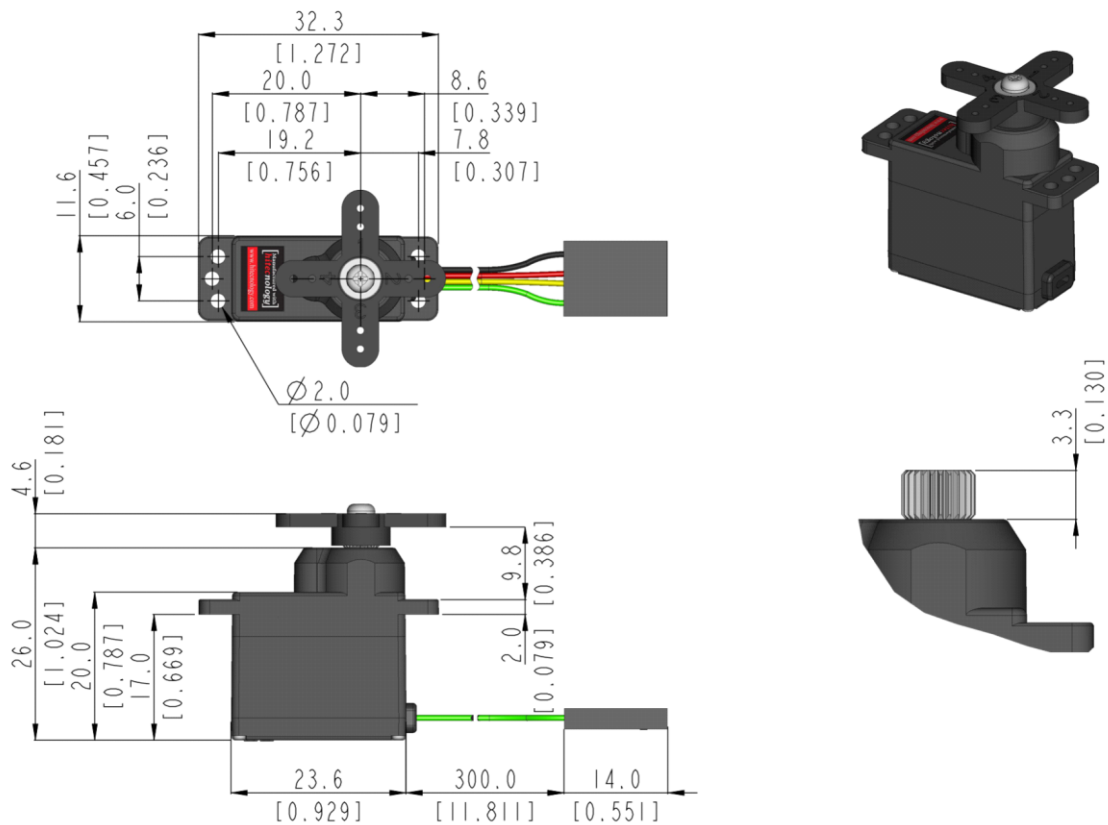

Control System	DroneCAN (UAVCAN v0)			-
Position Sensor Type	Contactless Magnetic Encoder			-
Motor Type	Cored Metal Brush			At the Max voltage, it is recommended to be used only for a short time duration.
Operating Voltage Range	4.0 ~ 8.4V			
Voltage	4.8V	6.0V	-	At 25°C(±10%), 45%RH(±10%) <u>measurement environment</u>
No Load Speed	0.14sec/60°	0.11sec/60°	-	
Stall Torque	1.8kgf-cm (25.0 oz-in)	2.2kgf-cm (30.55oz-in)	-	
Peak Efficiency Torque	0.4kgf-cm ( 5.55oz-in)	0.4kgf-cm ( 5.55oz-in)	-	
Standing Current	30mA	30mA	-	
No Load Running Current	180mA	220mA	-	
Stall Current	960mA	1,200mA	-	
Deadband	n/a	n/a	-	
Operating Travel	Servo Mode : ±60°(Default), ±150°(Programmable)			F/W v1.5 or Higher version
Continuous Rotation	n/a			-
Operating Temperature Range	-20°C ~ +60°C (-4°F ~ +140°F)			-
Storage Temperature Range	-30°C ~ +80°C (-22°F ~ +176°F)			-
Connector Wire Length	300mm (11.811inch)			
Connector Wire Gauge	28AWG			
Dimensions	23.6mm x 11.6mm x 26.0mm (0.929inch x 0.457inch x 1.024inch)			General Tolerance ±0.1mm
Weight	12.8g (0.452oz)			Excluding the weight of Horn
Bearing Type	1 Ball Bearing			-
Case Material	Engineering Plastic			-
Gear Material	1 Heavy Duty Resin & 4 Metal Gears			-
Gear Train Backlash	Max 0.5°			-
Horn Gear Spline	M25T(Ø5)			-
IP-Rating	IP4X			-
Servo Amplifier Type	32bit programmable Digital			-



1:1 scale (Unit : mm[inch])

- This product should not be used directly on the human body for medical purposes.
- All specifications are subject to change without notice.
- Be careful as strong magnetic fields may cause malfunction of the product.



9001:2015  
14001:2015  
CERTIFIED



HitecCS.com