

MD89MW-CAN General Specification.

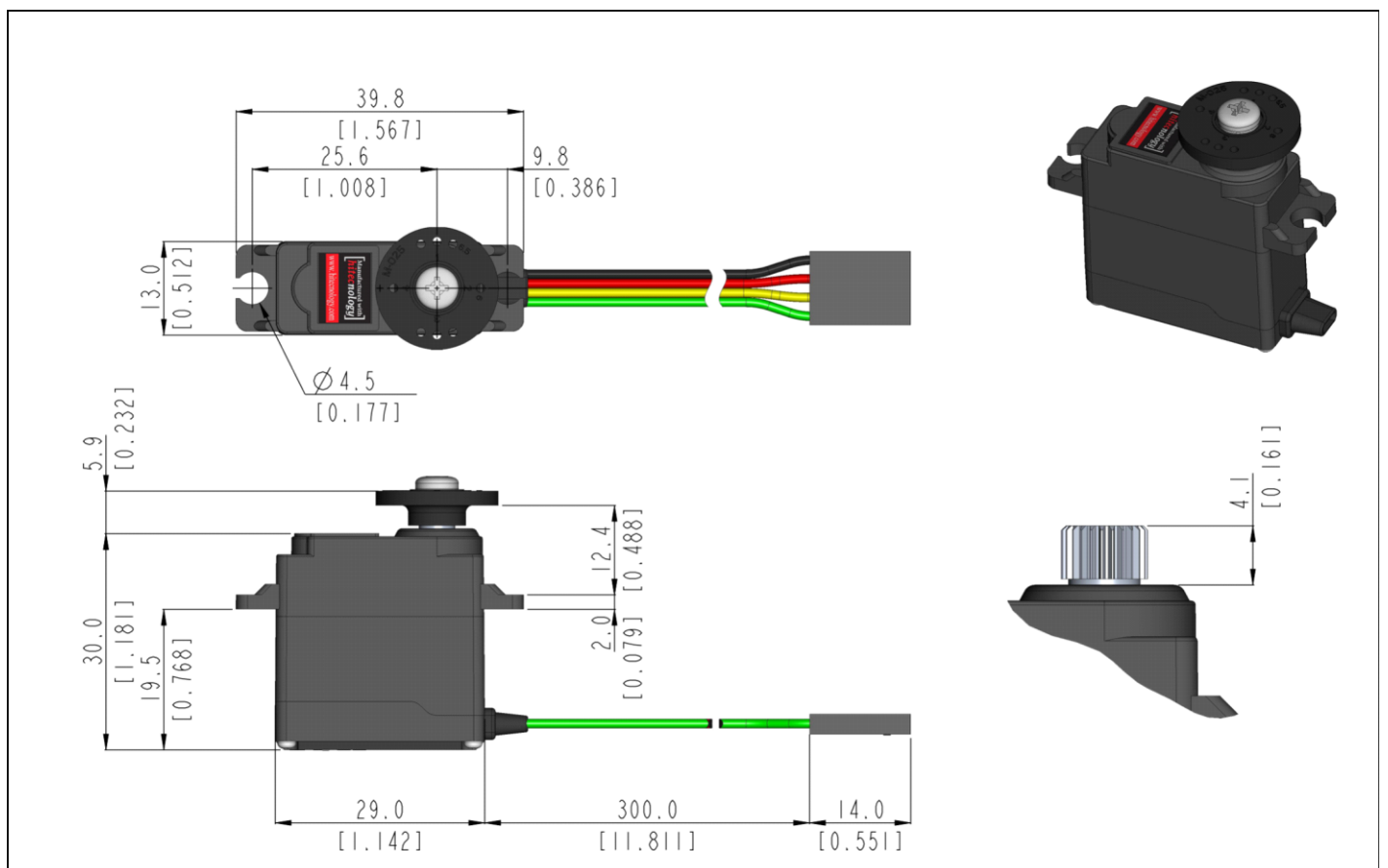

Control System	CAN 2.0A,B			-
Position Sensor Type	Contactless Magnetic Encoder			-
Motor Type	Coreless			At the Max voltage, it is recommended to be used only for a short time duration.
Operating Voltage Range	4.0 ~ 8.4V			
Voltage	4.8V	6.0V	7.4V	At 25°C(±10%), 45%RH(±10%) <u>measurement environment</u>
No Load Speed	0.17sec/60°	0.13sec/60°	0.11sec/60°	
Stall Torque	5.3kgf-cm (73.6 oz-in)	6.4kgf-cm (88.88oz-in)	8.5kgf-cm (118.04oz-in)	
Peak Efficiency Torque	1.1kgf-cm (15.28oz-in)	1.3kgf-cm (18.05oz-in)	1.7kgf-cm (23.61oz-in)	
Standing Current	30mA	30mA	30mA	
No Load Running Current	200mA	250mA	300mA	
Stall Current	1,800mA	2,200mA	2,700mA	
Deadband	n/a	n/a	n/a	
Operating Travel	Servo Mode : ±60°(Default), ±150°(Programmable) / Turn Mode : ±32760 Turns			F/W v1.5 or Higher version
Continuous Rotation	n/a			-
Operating Temperature Range	-20°C ~ +60°C (-4°F ~ +140°F)			-
Storage Temperature Range	-30°C ~ +80°C (-22°F ~ +176°F)			-
Connector Wire Length	300mm (11.811inch)			
Connector Wire Gauge	22AWG			
Dimensions	29.0mm x 13.0mm x 30.0mm (1.142inch x 0.512inch x 1.181inch)			General Tolerance ±0.1mm
Weight	28.0g (0.988oz)			Excluding the weight of Horn
Bearing Type	2 Ball Bearing			-
Case Material	Engineering Plastic			-
Gear Material	5 Metal Gears			-
Gear Train Backlash	Max 0.5°			-
Horn Gear Spline	25T(Ø6)			-
IP-Rating	IP4X			-
Servo Amplifier Type	32bit programmable Digital			-



1:1 scale (Unit : mm[inch])

- This product should not be used directly on the human body for medical purposes.
- All specifications are subject to change without notice.
- Be careful as strong magnetic fields may cause malfunction of the product.



HitecCS.com